

Applications:

- Rapid disaster deployment
- Handheld relay control for security officer empowerment (use for functions such as ingress / egress control or possible duress notifications)
- Random ID challenges
- Security officer booth / ID checks in trucks and buses
- Staff enrollment / asset tracking
- Mustering / emergency assembly points



Ordering Information	Credential technologies	Kit components
<b>HHR-3262-GY</b> (gray, UPC 816684007293) <b>HHR-3262-WH</b> (white, UPC 816684007309)	Low-frequency (125 kHz) Farpointe Prox, HID Prox, AWID Prox	<i>HHR-9062-GY / HHR-9062-WH Portable Proximity RF Card Reader/Dock</i>
		<i>HHR-6400 Card Reader base interface</i>
		<i>HHR-RCHL Card Reader charging unit</i>
<b>HHR-3266-GY</b> (gray, UPC 816684007316) <b>HHR-3266-WH</b> (white, UPC 816684007323)	High/low-frequency (13.56 MHz/125 kHz) HID Prox, Indala Prox, EM4102, AWID Prox; ISO14443A/B ISO15693, FeliCa™ (IDm); MIFARE Classic®, MIFARE DESFire® 0.6, MIFARE DESFire® EV1, HID: iCLASS® Standard/SE/SR/Seos; PIV II, Secure Identity Object® (SIO®)	<i>HHR-9066-GY / HHR-9066-WH Portable Proximity RF Card Reader/Dock</i>
		<i>HHR-6400 Card Reader base interface</i>
		<i>HHR-RCHL Card Reader charging unit</i>
(HID Reader Module) Global Certifications: UL Recognition (Recognized Component) to UL294 for the USA and CSA C22.2 No. 205 for Canada. CE, FCC 47 Part 15 modular approval, RoHS, WEEE		
(HID Reader Module) Government Approvals: FIPS 201 PIV II with inclusion on GSA APL		
<b>HHR-3267-GY</b> (gray, UPC 816684007415) <b>HHR-3267-WH</b> (white, UPC 816684007422)	High-frequency (13.56 MHz) Farpointe Sector, HID iClass® CSN/UID Outputs	<i>HHR-9067-GY / HHR-9067-WH Portable Proximity RF Card Reader/Dock</i>
		<i>HHR-6400 Card Reader base interface</i>
		<i>HHR-RCHL Card Reader charging unit</i>
<b>HHR-3268-GY</b> (gray, UPC 816684001536) <b>HHR-3268-WH</b> (white, UPC 816684001543)	High-frequency (13.56 MHz) HID Prox, Indala Prox, EM4102, AWID Prox; ISO14443A/B ISO15693, FeliCa™ (IDm); MIFARE Classic®, MIFARE DESFire® 0.6, MIFARE DESFire® EV1, HID: iCLASS® Standard/SE/SR/Seos; PIV II, Secure Identity Object® (SIO®)	<i>HHR-9068-GY / HHR-9068-WH Portable Proximity RF Card Reader/Dock</i>
		<i>HHR-6400 Card Reader base interface</i>
		<i>HHR-RCHL Card Reader charging unit</i>
(HID Reader Module) Global Certifications: UL Recognition (Recognized Component) to UL294 for the USA and CSA C22.2 No. 205 for Canada. CE, FCC 47 Part 15 modular approval, RoHS, WEEE		
(HID Reader Module) Government Approvals: FIPS 201 PIV II with inclusion on GSA APL		
<b>HHR-3269-GY</b> (gray, UPC 816684002120) <b>HHR-3269-WH</b> (white, UPC 816684002137)	Low-frequency (125 kHz) HID Prox, Indala Prox, EM4102, AWID Prox; ISO14443A/B ISO15693, FeliCa™ (IDm); MIFARE Classic®, MIFARE DESFire® 0.6, MIFARE DESFire® EV1, HID: iCLASS® Standard/SE/SR/Seos; PIV II, Secure Identity Object® (SIO®)	<i>HHR-9069-GY / HHR-9069-WH Portable Proximity RF Card Reader/Dock</i>
		<i>HHR-6400 Card Reader base interface</i>
		<i>HHR-RCHL Card Reader charging unit</i>
(HID Reader Module) Global Certifications: UL Recognition (Recognized Component) to UL294 for the USA and CSA C22.2 No. 205 for Canada. CE, FCC 47 Part 15 modular approval, RoHS, WEEE		
(HID Reader Module) Government Approvals: FIPS 201 PIV II with inclusion on GSA APL		



HHR-3260\_170824

## Benefits of the Cypress Handheld Wireless Reader System

The Cypress Handheld Wireless Reader verifies credentials by wirelessly communicating with a live database through the reader's Base Unit. A vend button on the Handheld Reader controls a relay, which can be used for functions such as controlling doors or gates, or triggering possible duress notifications.

Designed for transportation and cargo facilities; petrochemical, manufacturing, and military sites; and healthcare and educational campuses.

Specifications			
Physical	Handheld Reader		6.81" x 3.63" x 1.58" / 1.2 lbs
	Charging Dock		4.758" x 4.1" x 2.2" / 0.35 lbs
	Base Unit		9.25" x 7.0" x 2.25" / 1.3 lbs
Environmental	Temperature Range		-17 to 54 C
	Base Unit		Weatherproof Enclosure - ABS - IP65
Electrical	Base Unit Supply Voltage		8-16Vdc Current 300mA
	Handheld Reader Internal LiPo Battery Pack		7.4V 3800mAh Rechargeable (not field-serviceable)
	Charging Dock		120 Vac wall plug
Radio	Frequency		2.4 GHz ISM band
	Type		Direct Sequence Spread Spectrum (DSSS)
	Transmit Power		15 dBm
	Receiver Sensitivity		-103 dBm (1% PER, 250Kbps)
	Modulation		O-QPSK
	Agency Approvals		FCC Part 15.247: FCC ID: U90-SM220
			Industry Canada (IC): 7084A-SM220
			CE Certified: Certified to EN300 328 Version 1.8.1
Security Encryption		AES encryption upon request (export restrictions may apply)	
Wireless range	Indoor	Maximum of 150 feet*	
	Outdoor	Maximum of 500 feet*	
	*Note: Distances are typical line-of-sight. Actual distance may vary depending upon terrain, RF environment, building materials, and height of antenna.		
Additional Features	AES encryption for secure communications (upon request)		
	Vend button controls a relay for functions such as operating gates or possible duress notification		
	Handheld Reader's gate selection feature can be used for ingress and egress lanes or gates		
	Channel selection is factory-configured		
	Diagonistic indicator on base unit for determining operational status of the unit		
	Optional Repeaters extend distance and bypass line-of-sight issues		

## Table of Contents

<b>Topic</b>	<b>Page</b>
Credential Technologies & Ordering Information	1
Benefits of the Cypress Handheld Wireless ReaderSystem	2
Specifications	2
Cable recommendations	4
Unpacking system components	4
Important safety information	4
Bench testing	5
System overview	5
Field installation and testing	6
Handheld Reader diagram	7
LED indicators	7
Pin layout, Base Unit	8
Base Unit and access control panel interface / wiring diagram	9
Addendum: Handheld Reader channel and address programming	10
Addendum: Reconfiguring the Base Unit radio	11
Addendum: Using the Handheld Wireless Reader system with a Cypress Repeater	12

## HHR-3260 Series Base Unit Cable Recommendations

Wiegand and LED

PVC - Belden 9873 - 20 AWG 3 pair shielded, 500 feet max.

Plenum - Belden 83606 or 85164 - 20 AWG 3 pair shielded, 500 feet max.

Power (local)

PVC - Belden 8461 - 18 AWG 1 pair, 25 feet max.

Plenum - Belden 82740 - 18 AWG 1 pair, 25 feet max.

### Unpacking

- Remove packaging from units and check interior of Base Unit for any shipping damage.
- Inventory any included parts (depending on model).



Base Unit  
HHR-6400



(2) Handheld Rdrs / Docks  
(See pg. 1 for part #)



Reader Holster (opt.)  
HHR-HOL3



(2) Chargers  
HHR-RCHL



Repeater (opt.)  
RPT-5651



Program cards (opt.)  
HHR-CPC1/APC1

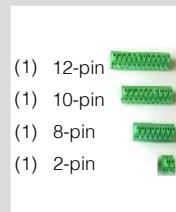

(1) 12-pin  
(1) 10-pin  
(1) 8-pin  
(1) 2-pin

4 Connectors



Quick-Start Guide



Warranty

### IMPORTANT SAFETY INSTRUCTIONS AND WARNINGS For LiPo BATTERIES

It is important to specifically use a Lithium Polymer/Li-ion charger only. Do not use a NiMH or NiCd charger. Failure to use the proper charger may cause a fire, which could result in personal injury and property damage.

Never charge batteries unattended. When charging LiPo/Li-ion batteries, batteries should constantly be observed to monitor the charging process to ensure batteries are being charged properly and to respond to potential problems which may occur.

Some LiPo/Li-ion chargers on the market may have technical deficiencies and charge the LiPo/Li-ion batteries incorrectly or at an improper rate. It is your responsibility to ensure the charger you purchased works properly.

If at any time a battery begins to heat, smoke, swell, or balloon, immediately stop charging the battery and disconnect the charger, then observe the battery in a safe place for approximately 15 minutes, since the battery could leak and react with air, causing chemicals to ignite and result in a fire. Since delayed chemical reaction can occur, it is best to observe the battery as a safety precaution, in a safe area outside of any building or vehicle and away from any combustible material.

## Bench Testing

### Basics:

- Before field-installing units, they should be tested at a convenient bench top location. This will make it easier to verify / change settings and check operation when both units are visible, instead of far apart.
- Handheld Readers and Base Unit should be at least 24 inches apart.
- The Base Unit needs a suitable 8-16 Vdc power supply connected.
- The units as shipped are configured as a matched set and are ready to power up and operate.
- Be sure Handheld Readers are fully charged by connecting the charger cables and charging docks, plugging the chargers into an outlet and placing Readers in the charging docks (approximately 4 hours).
- The Base Unit contains two boards. Board A and Board B (see pg. 8).
- In general, the Base Unit is installed similar to two fixed readers connected to an access control panel. Board A and Board B are connected to two separate Wiegand ports.
- Review product manual, including Handheld Reader Features and LED Indicators (pg. 7), and HHR-6400 Base Unit Pin Layout (pg. 8).

### Bench Testing:

1. Run the following wires between the Base Unit Board A to a Wiegand port on the access control panel: Data 0, Data 1, common ground, LED input.
2. Run the following wires between the Base Unit Board B to a separate Wiegand port on the access control panel: Data 0, Data 1, common ground, LED input.
3. Connect a suitable power supply to the Base Unit Board A and Board B (8 - 16 Volts dc; minimum of 600mA).
4. *Test whether Readers are communicating with the Base Unit's Board A and Board B:* Press the Power button on the Handheld Reader. The Reader's Red LED will illuminate when powered on, and its Blue LED will blink continuously when the Reader is communicating with the Base Unit. The Status LED on the Base Unit's Board A will flash green when the first reader is connected. Repeat this process, but instead using the second Reader and Board B.
5. *Test a simulated valid badge read:* Temporarily connect a wire to the "LED In" and "Ground" on the Base Unit's Board A. While it is connected, each Handheld Reader's Green LED will be illuminated and the vibrate motor will be active. Disconnect the wire when finished. Repeat this process for the second Reader, but instead using the second Reader and Board B.
6. *Test each Handheld Reader's relay control:* Press the Relay Control (Vend) button. The Reader will briefly vibrate and the Base Unit's Board A will emit an audible click. Relay activity can also be tested with a voltage meter set to continuity mode and monitoring the change in state of the Relay 1 Output pins. Repeat this process, but instead using the second Reader and Board B.
7. Once the Bench Test steps are completed, the Base Unit is ready to be installed at its permanent location, and the Handheld Reader System is ready to be used.

## Overview: How the System Functions

The Handheld Reader system reads Wiegand RF proximity badges and sends badge data to its Base Unit through a radio link. The Base Unit, which is installed similar to a standard fixed-mount reader, interfaces with an access control panel.

An access control panel determines whether the badge is valid or invalid. When valid badge data is presented, the panel will trigger an LED, Strike Relay output, or both, depending upon the type of panel.

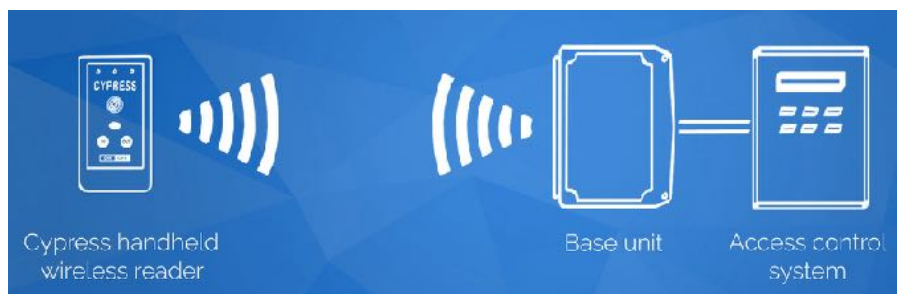

## Field Installation

### A. Determine Base Unit location

1. The Base Unit should be mounted at a site which allows maximum range between the Base Unit and the Handheld Readers. *Typical maximum range for the wireless connection between the Handheld Readers and the Base Unit are 150 feet line-of-sight indoors, or 500 feet line-of-sight outdoors.*
2. It is not recommended to locate the Base Unit directly above the area where Handheld Readers will be used, as communication issues may occur.
3. The Base Unit location must accommodate a wired connection to the access control panel.

### B. Mounting the Base Unit

1. *Recommendation: Temporarily place the Base Unit at its desired mounting location. Use a battery to power up the Base Unit and test the wireless connection between the Base Unit and the Handheld Readers (See Handheld Reader testing steps, below).*
2. In general, the Base Unit should be mounted at least 10' above the ground outdoors, or 5-6' above the floor indoors, and should not be mounted directly above the area where Handheld Readers will be used. If obstacles are present (vehicles, trains, buildings, trees, etc.) choose a location high enough to avoid interference.
3. A non-metal mounting surface is recommended for the Base Unit, as metal surfaces will reduce the effective range between the Base Unit and the Handheld Readers. If use of a metal surface is unavoidable, space the Base Unit as far from the metal surface as possible using a plastic, wood, or other non-metal spacer.
4. Mount the Base Unit in the upright position. When correctly oriented, "Cypress" can be clearly read.

### C. Connecting the Base Unit to the access control panel

1. To properly connect the HHR-6400 Base Unit to the access control panel, 2 Wiegand ports must be available on the panel.
2. From Board A in the Base Unit, connect Data 0, Data 1, common ground, and LED Input to the available Wiegand ports. Refer to the wiring diagram on pg. 9 as needed.
3. From Board B in the Base Unit, connect Data 0, Data 1, common ground, and LED Input to the available Wiegand ports. Refer to the wiring diagram on pg. 9 as needed.
4. To power Board A and Board B Base Unit, connect the power supply to Board A and Board B with an 8-16Vdc power supply, with a minimum of 600mA of current.

### D. Testing the Handheld Reader-to-Base Unit connection

1. Be sure the Handheld Readers have been charged for at least 4 hours prior to testing.
2. Press the Power button on each Handheld Reader. The Reader's Red LED will illuminate, and its Blue LED will blink continuously when the Reader is communicating with the Base Unit. The LED on the Base Unit's board will also flash green.
3. To simulate a valid badge read, temporarily connect a wire to the "LED In" and to a ground pin on the board in the Base Unit. While it is connected, each Handheld Reader's Green LED will be lit and the vibrate motor will be active.
4. To test each Handheld Reader's relay control, press the Relay Control (Vend) button. The Reader will briefly vibrate and the Base Unit board will emit an audible click. Relay activity can also be tested with a voltage meter set to continuity mode.
5. Test with a valid badge by presenting the badge to each Handheld Reader. If all connections to the panel are made correctly, the Reader's Green LED will illuminate and the Reader will vibrate.

**Note:** *If there is no direct line of sight, if obstacles are present, or if additional distance is needed between the Base Unit and Handheld Reader, a Cypress Repeater unit is recommended. See pg. 12.*

## LED Indicators (Handheld Reader and Base Unit)

### Handheld Reader LEDs

- Red LED (top left - power & card acknowledge)  
Illuminated: Handheld Reader's power button is activated and unit is on.  
Briefly blinks off then illuminates: A badge has been sensed.
- Blue LED (top center - communication status)  
Blinks continuously: Handheld Reader is communicating with Base Unit.  
Not lit: Reader is not communicating with the Base Unit.
- Green LED (top right - card verification)  
Illuminated: Valid badge. Reader should also vibrate.

### Base Unit Diagnostic LEDs

The Base Unit's board has a diagnostic LED, located between the 2-pin and 8-pin header.

The diagnostic LED is bi-color and may display red, green, or red and green, depending on the status.

- When the Handheld Reader is communicating with the Base Unit, the Base Unit's diagnostic LED will continuously flash green.
- When the Handheld Reader is powered off or not communicating with the Base Unit, the Base Unit's diagnostic LED flashes red and green.

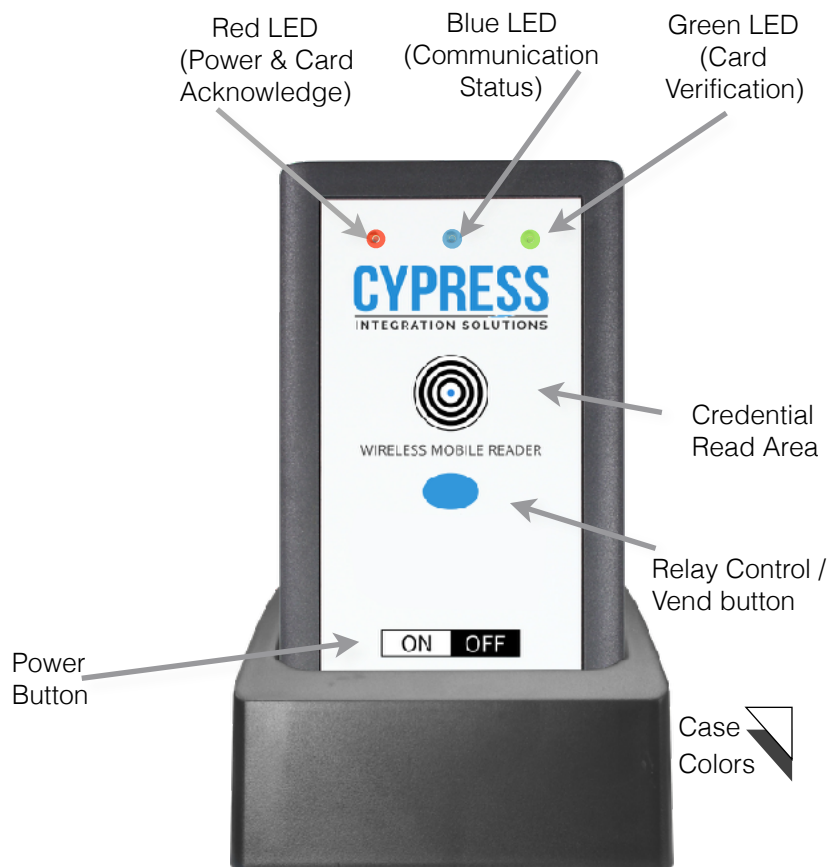

Handheld Reader Kit includes Handheld Reader (shown), Charging Dock, and Base Unit.

See Credential Technologies and Ordering Information, pg. 1.



# HHR-6400 Pin Layout

## BOARD A

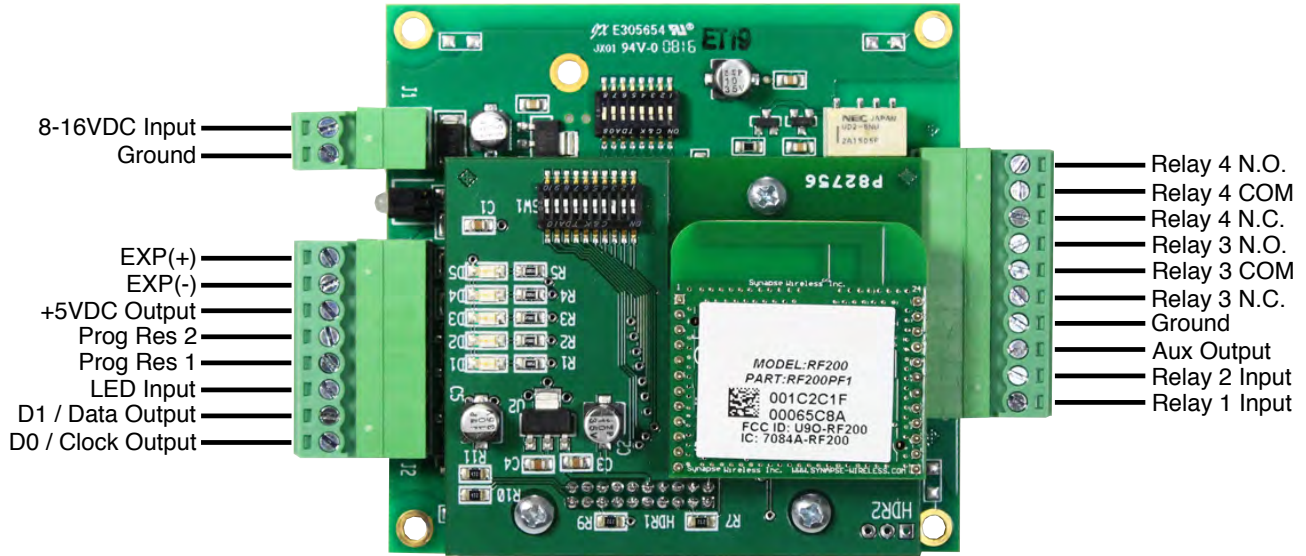

## BOARD B

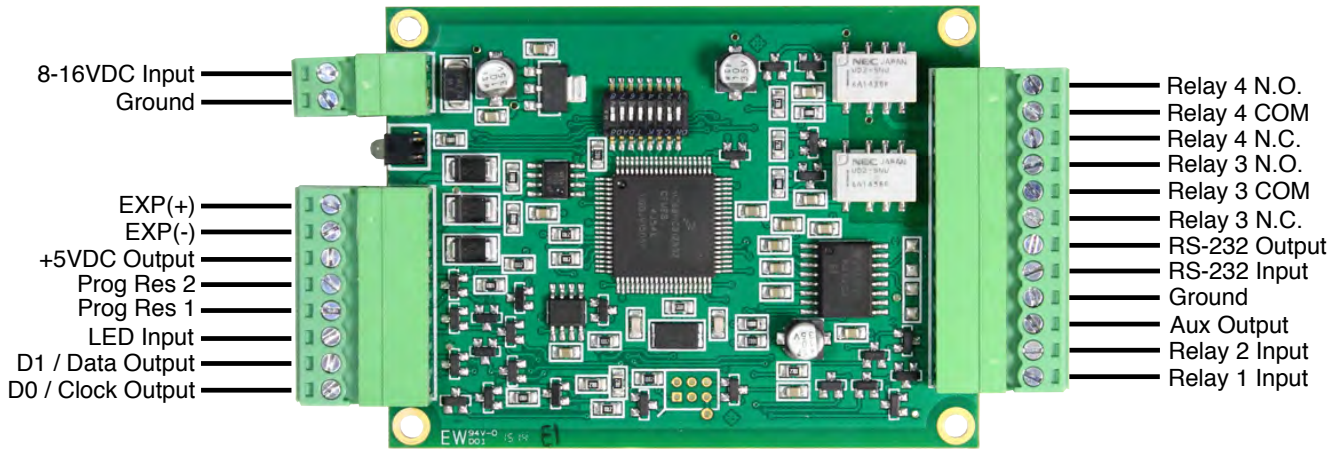



# HHR-6400 - Wiegand Base Unit Panel Interface

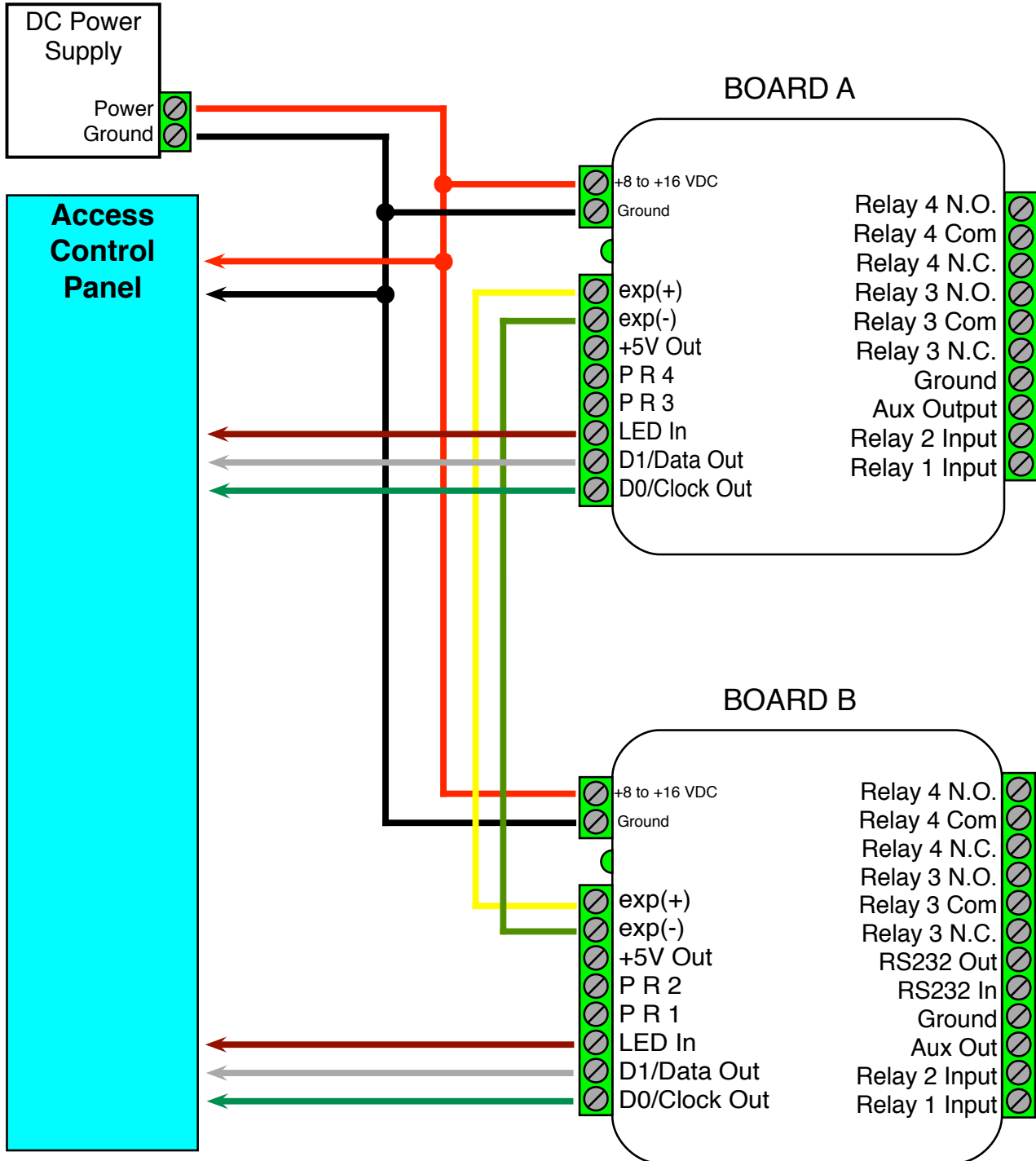

## ADDENDUM

### Handheld Reader Channel and Address Programming

Handheld Readers will provide for field selection of Channel (2-14) and Network Address (0-1) using programming cards. The channel programming cards (Part no. WMR-PRC1-99) are labeled Channel 2-14. Handheld wireless networks are separated through the use of separate channels. A Reader is shipped preconfigured to communicate with its Base Unit over one specific channel. If it becomes necessary to configure channels using the programming cards, follow the instructions below. Note: Address and Channel Programming cards are used only with the Handheld Reader, not the Base Unit.

#### To change the channel of the Base Unit

1. Remove power from the Base Unit.
2. Using the diagram on pg. 8 of this document as a reference, modify the DIP switches of the Base Unit for the desired channel.
3. Apply power to the Base Unit.
4. Observe that the Base Unit no longer communicates with the Handheld Reader.

#### To change the channel of each Handheld Reader

1. Turn the Handheld Reader on by pressing the power button momentarily.
2. Observe that it is not communicating with the Base Unit.
3. Present the desired channel programming card.
4. Observe the Red LED wink for 1/2 second indicating the card was read.
5. The Blue LED should start blinking indicating that it is communicating with the Base Unit.

#### Card Programming - Troubleshooting

*For all Handheld Reader steps indicated above, the following error conditions may occur.*

Step 2 - If the Red LED does not illuminate, the batteries may need to be replaced or charged.

Step 4 - If you do not see the Red LED wink out for 1/2 second, present the badge again.

- If the Red LED still does not indicate a badge read has occurred, then there may be a problem with the Reader.

- When trying multiple times, make sure the badge is at least 1 foot away from the Handheld Reader before presenting the badge again.

- Allow the unit to power off for 1 minute and try again.

#### Change the address of the Handheld Reader

*For Handheld Readers with the built-in In/Out Gate Selection feature, address programming cards are redundant. If it is necessary to configure addresses using the programming cards, follow these steps:*

1. Turn the Handheld Reader on by pressing the power button momentarily.
2. Present the desired address programming card.
3. Observe the Red LED wink for 1/2 second indicating the card was read.
4. Handheld Reader should now be on the address labeled on the programming card and be communicating with the Base Unit.

#### Sample Channel card

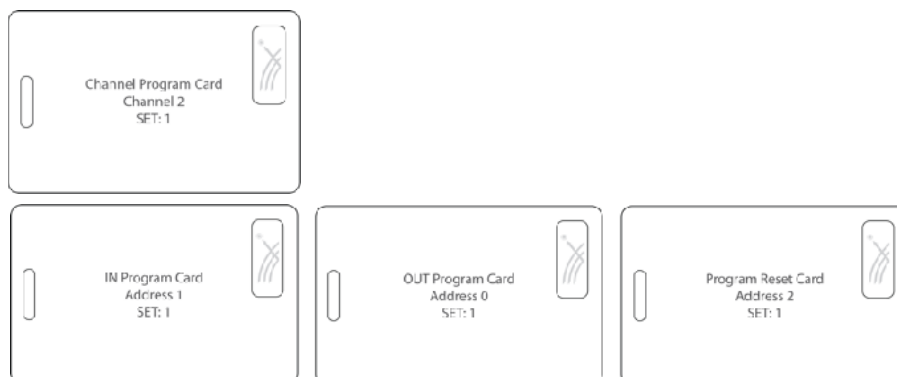

## Reconfiguring the Base Unit Radio

Units in the Handheld Reader Kit are factory-configured to communicate with each other. Use the 10-position DIP switch bank on the daughterboard to re-configure radio settings as necessary for the following applications:

- Changing the channel of the radio
- Changing the Handheld Reader display outputs to show radio energy in the environment, or the link quality between the Handheld Reader and Base Unit radios

### Daughterboard

The daughterboard is located on the Base Unit board.

The daughterboard has a 10-position DIP switch bank and LED display.

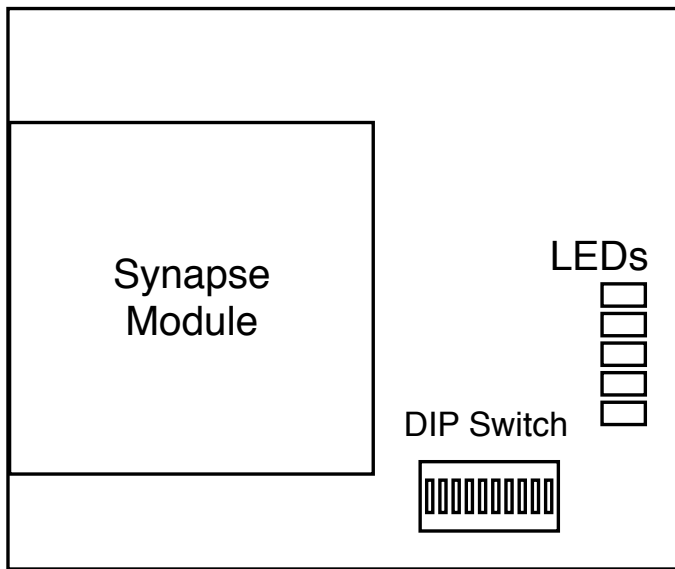

### Channel

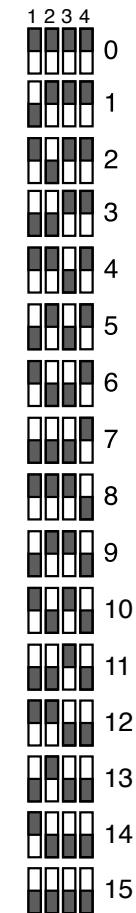

### Changing the Channel

Changing the channel requires using DIP switches 1-4 on the daughterboard DIP switch bank. The diagram at left shows all the possible channel configurations.

Set DIP switches 1-4 according to the channel that will be used.

When changing the channel, the Base Unit must be power-cycled after setting the DIP switches to the desired channel.

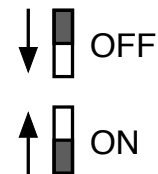

### Signal Strength Meter

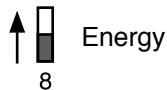
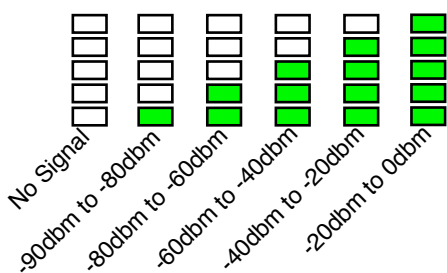

The ambient RF energy of the selected channel regardless of network ID.

### Changing the Handheld Reader display outputs

When DIP switch 8 is on, the LEDs will display the ambient RF energy in the area.

This can be used to determine if the intended channel has a high level of noise.

## Typical Handheld Installation with Optional Repeater



### Basics:

The Cypress Repeater is used to get around obstacles that prevent a clear line of sight between the Handheld Reader and the Base Unit. It is mounted similar to the Base Unit. Please review pg. 6.

### Installation:

Find a suitable location for the Cypress Repeater Unit between the area where the Handheld Reader will be used and the Base Unit. There should be a clear line of sight between the Repeater and both units. Mount the Repeater at the same height at which the Base Unit is mounted, preferably on a non-metal surface.

Connect a power supply to the Repeater.

Once the Repeater has power, the status LED on the main board will stay solid green. The Repeater will now repeat any signals received from the Handheld Reader and Base Unit. If communication problems still exist, it may be necessary to relocate the Repeater.